

# CHUTONG ELECTRIC CO LIMITED

## Work light

	Item number:CH53WK Swing Arm 410mm*2
	20W 2000LM 24W 2200LM
	AC100-240V Dimmable/non dimmable Body:white/ESD black

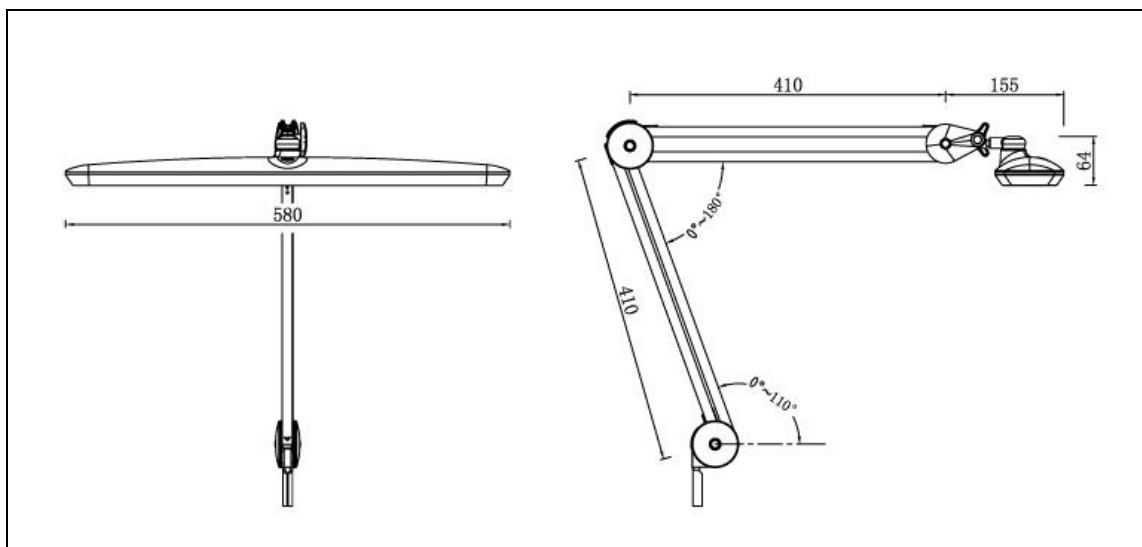

### Product Description

An industrial quality daylight balanced task light.

Features a long 20-inch shade and a long-reach swing arm designed for any work bench or desk. Great for inspection of small parts, stamp collecting, crafts and hobbies

Features:

100pcs Daylight Balanced LED; 17W

20" x 3.5" shade area uniformly illuminates work area

410MM\*2 Spring Balanced Swing Arm stays set in any position.

clamp for mounting to desk, workbench, table, etc.

Industries usage Mfg, Assembly, Inspection, QA, Scientific, Medical, Forensics, etc.

110/220V-60Hz; 5-foot power cord. For indoor use only.

# CHUTONG ELECTRIC CO LIMITED

Appliation: Jewelry Making Industry, Welding Machine,PCB Maintenance



BASE: Clamp/Floor base/Desk

