

# CHUTONG ELECTRIC CO LIMITED

## Magnifying led lamp

CHTG8005Led clamp

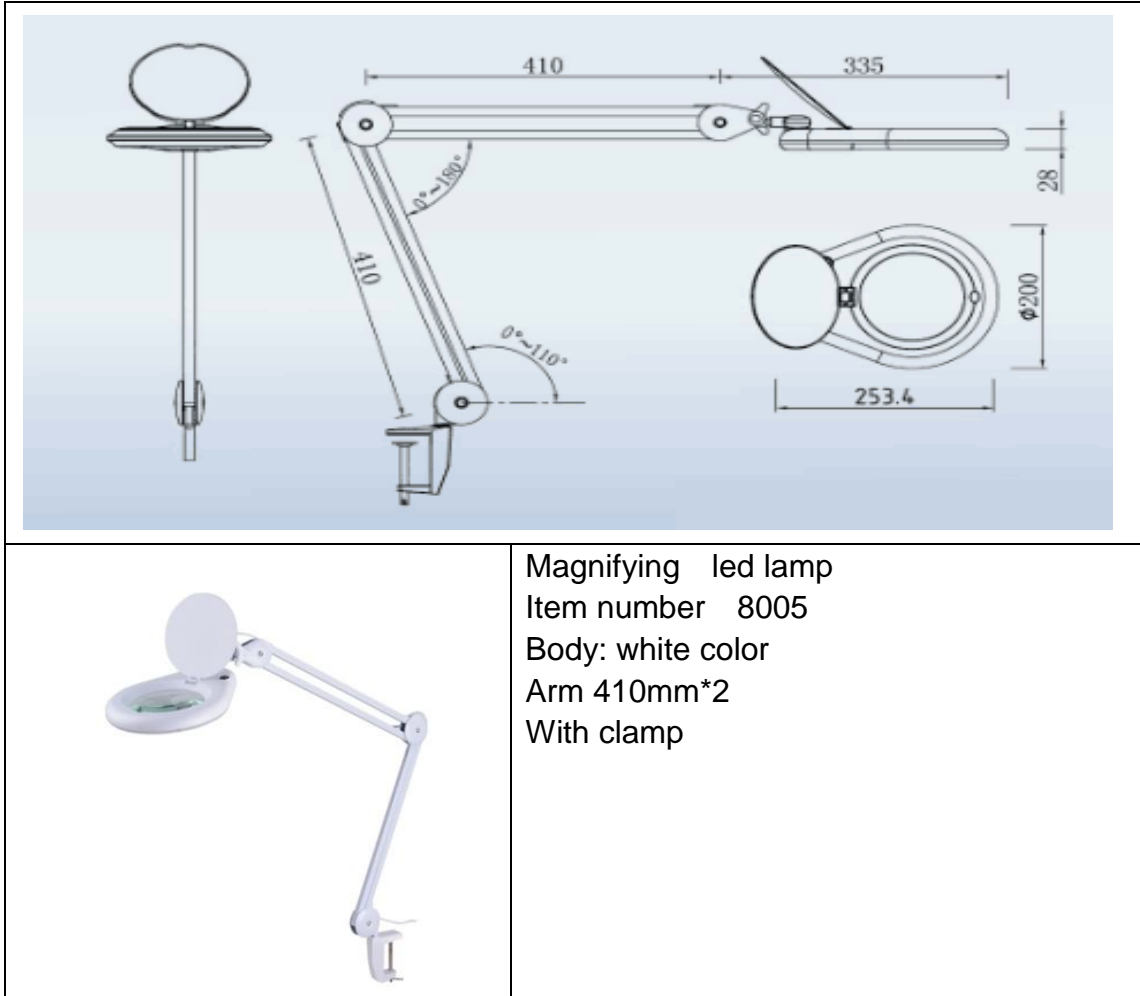

Magnifying led lamp  
Item number 8005  
Body: white color  
Arm 410mm\*2  
With clamp

Magnifier series can be used by circuit board test, stamp collector, infirmary, beauty parlor, reader, amateur, engineer. It can amplify 5 to 20 times.

Magnifying lamp Features:

- Lens: optical glass lens 127mm
- Magnification: 5X
- Structure: Full metal construction on body, lamp casing and clamping holder
- Arm: foldable 41CM\*2(with clamp or casters base)
- Light source: LED
- Power input: 100V-240V
- Base: weighted base /clamp 5.5mm/universal Casters 60cm height

( -----to be continue nex page-----)

# CHUTONG ELECTRIC CO LIMITED

---

## Magnifying lamp application

1 suitable for circuit board inspection, processing, installation at electronics industry. Electronic engineers to observe and test the micro elements, components of dense circuit board

2 suitable for engraving, fine operation and observation.

3 suitable for simple surgical operation. Enlarge the lighting for beautician and medical staff

